

**CODOLI  
A SALDARE DI  
TESTA  
PER TUBO GAS**

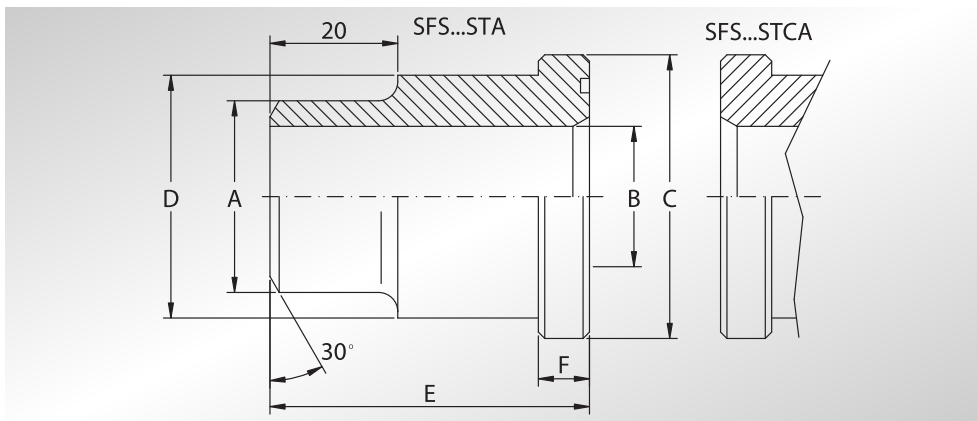

**WELD  
ON ADAPTERS  
FOR BSP TUBE**



Pressione max di esercizio raccomandata Kg/cm <sup>2</sup>	Grandezza	Tipo	Dimensioni						Or tipo	Peso Kg
			Dimensions							
Maximum recommended working pressure Kg/cm <sup>2</sup>	Size	Type	A	B	C	D	E	F	Or type	Weight Kg
			<b>SERIE 3000</b>							
345	1/2"	SFS301STA21	21,5	13	30,2	24	41	6,73	4075	0,08
345	3/4"	SFS302STA28	28,0	19	38,1	32	50	6,73	4100	0,16
345	1"	SFS303STA34	34,0	25	44,4	38	50	8,00	4131	0,23
276	1"1/4	SFS304STA42	42,8	32	50,8	43	55	8,00	4150	0,30
207	1"1/2	SFS305STA48	48,6	38	60,3	50	57	8,00	4187	0,40
207	2"	SFS306STA61	61,0	51	71,4	62	57	9,53	4225	0,50
<b>SERIE 6000</b>										
414	1/2"	SFS601STA21	21,5	13	31,8	24	34	7,75	4075	0,08
414	3/4"	SFS602STA28	28,0	19	41,3	32	38	8,76	4100	0,15
414	1"	SFS603STA34	34,0	25	47,6	38	40	9,53	4131	0,23
414	1"1/4	SFS604STA42	42,8	32	54,0	44	45	10,29	4150	0,30
414	1"1/2	SFS605STA48	48,6	38	63,5	51	50	12,57	4187	0,50
414	2"	SFS606STA61	61,0	51	79,4	67	58	12,57	4225	0,80

**DESIGNAZIONE PER ORDINE  
DESIGNATION FOR ORDER**

Codolo con sede o-ring  
Adapter with o-ring groove

Codolo senza sede o-ring  
Adapter without o-ring groove

**Materiale / Material**

A105 o similare (or similar)

AISI 316L

**SFS...STA**

**SFX...STA**

**SFS...STCA**

**SFX...STCA**

**NOTE / NOTES**