

**FLANGE QUADRE
ISO 6164**

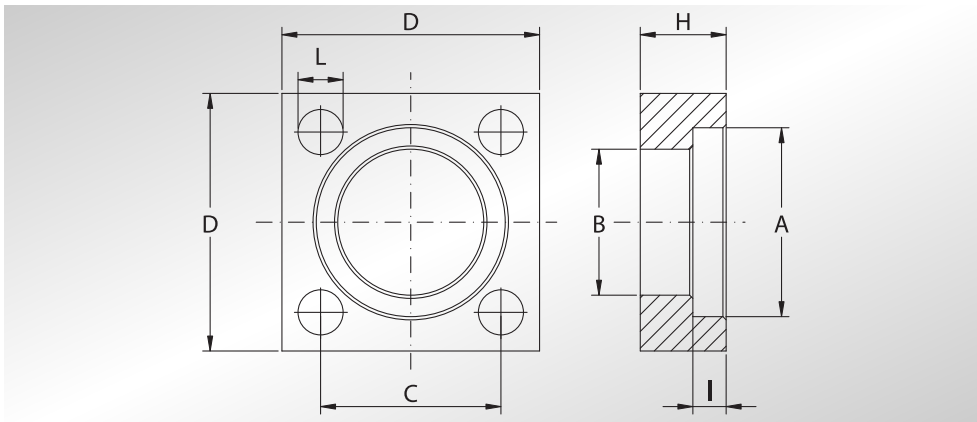

**SQUARE FLANGES
ISO 6164**



Pressione max di esercizio raccomandata Kg/cm ²	Grandezza	Tipo	Dimensioni								Peso Kg
Maximum recommended working pressure Kg/cm ²	Size	Type	Dimensions								Weight Kg
			A	B	C	D	H	I	L		
SERIE 6000											
400	2"	Q2ST400	80,2	67,60	69,4	100	40	12,2	17,5	1,26	
400	2"1/2	Q212ST400	95,0	80,50	83,4	120	50	16,1	22	2,37	
400	3"	Q3ST400	111,0	90,50	102,5	150	52	16,1	26	3,20	
400	4"	Q4ST400	136,0	114,50	123,7	180	70	21,0	33	9,95	

DESIGNAZIONE PER ORDINE DESIGNATION FOR ORDER	Materiale / Material A105 o similare (or similar)
--	--

NOTE / NOTES

Solo flangia
Only flange

Q...ST400

